

FROSCO

FROSGOLD

FROSCO DRAINAGE PRODUCTS



Product Available in:-
- Ductile Iron
- Cast Iron
- Aluminium

Stainless Steel Material
Available in:-
SUV 316
SUV 304
SUV 439

SIRIM TESTED



23 July 2018

INTRODUCTION

FROSCO Drainage Product Heavy Duty

Scupper Drain

To provide drainage from roof surface horizontally through parapet. Provide vertical drainage by reversing outlet.

Roof Drain (RC Flat Roof)

Provide efficient drainage of waste water from surrounding flat roof areas direct to the waste pipe system. The dome-shaped cover prevents the rubbish and debris from blocking of waste water into waste pipe system

Floor Drain (RC Floor)

Provide efficient drainage of waste water from surrounding floor areas direct to the waste pipe system. The adjustable strainer enable exact height adjustment to the finished floor level.

Scupper Drain (RC Gutter/Abulution)

Gully Trap

Stainless Steel Model Light and Medium Duty

Floor Drainage

Rain water Harvesting

FROSCO Scupper Drain MODEL: FSD-700

1. Lacquered duty iron body.
2. Aluminium or Nickel Bronze or Ductile iron sloping grate & flashing clamp.
3. Outlet Pipe Size :
 - A : 100 mm \varnothing
 - B : 75 mm \varnothing
 - C : 50 mm \varnothing

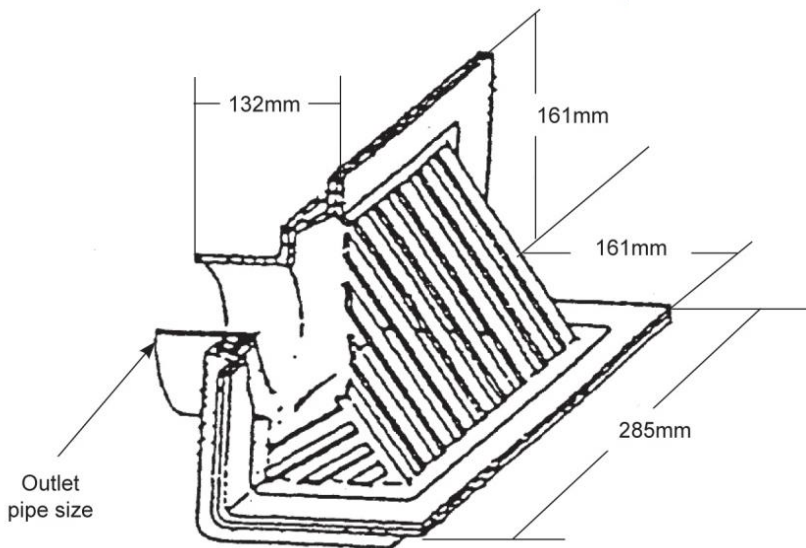

We reserve the right to make improvement or changes without notice

FROSCO FLOOR DRAIN MODEL (FFD-800SQ SERIES) (Body Ductile Iron/Nickel Bronze or Cast Iron Strainer & Grating)

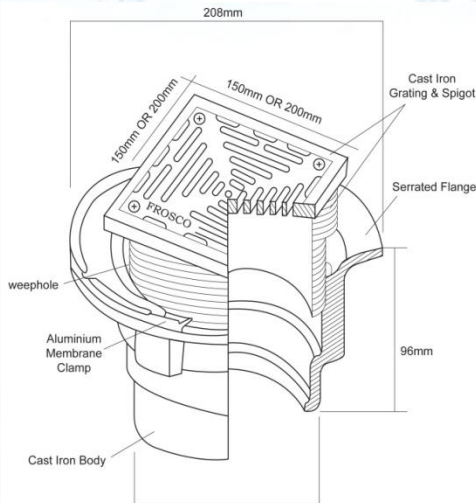

Outlet Pipe Size A, B, C & D

Grating	- Cast iron/ Nickel Bronze
Body	- Cast iron
Spigot	- Cast iron
Membrane Clamp	- Aluminium
Outlet Pipe Size :	
A :	150 mm ϕ
B :	100 mm ϕ
C :	75 mm ϕ
D :	50 mm ϕ

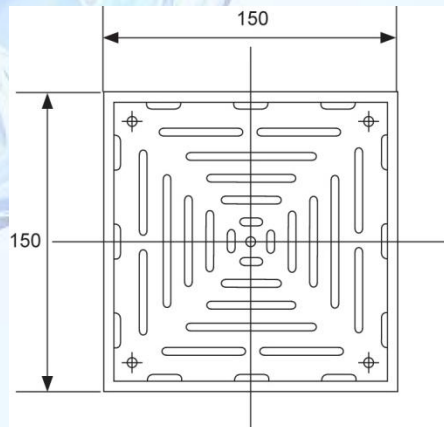
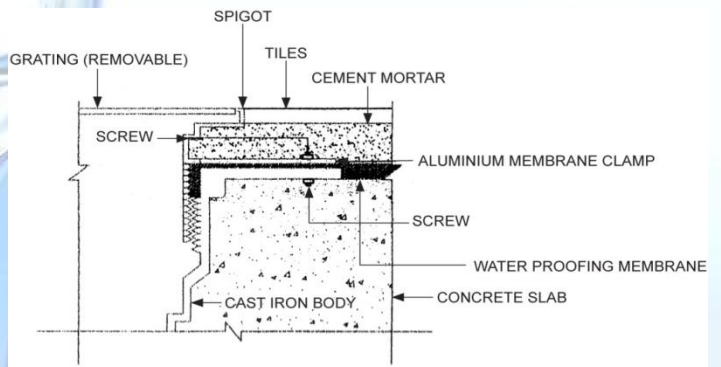
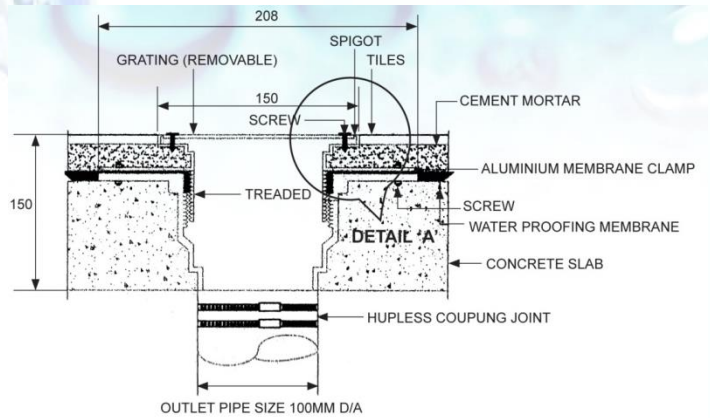

FROSCO FLOOR DRAIN MODEL (FFD-800R SERIES)

Body Ductile Iron/Nickel Bronze or Cast Iron
Strainer & Grating
(Round Strainer c/w Membrane Clamp)

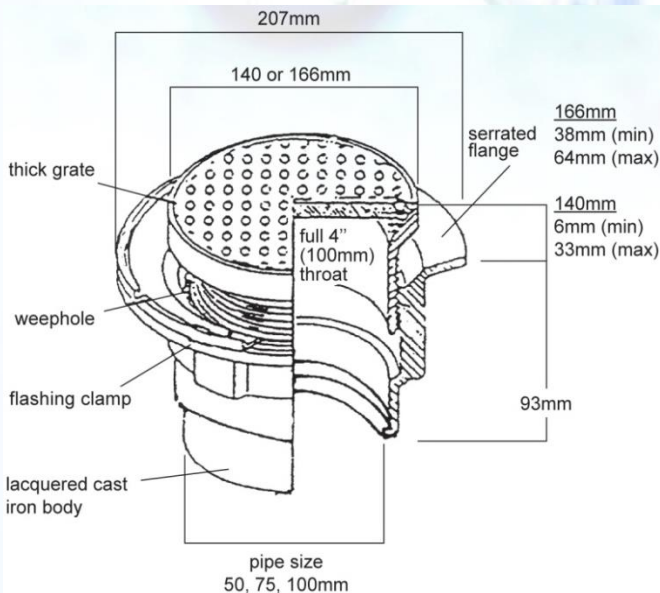

FFD-800R

1. Lacquered ductile iron body
2. Aluminium Membrane flashing clamp
3. Adjustable Strainer – Stainless Steel, aluminium or Nickel Bronze
4. Size of strainer :
4"x4", 6"x6", 8"x8" or 12"x12"
5. Outlet Pipe Size :
A : 150 mm \varnothing
B : 100 mm \varnothing
C : 75 mm \varnothing
D : 50 mm \varnothing
6. Perforated stainless steel sediment bucket (optional)

FFD 820 R FFD 820 SQ

1. Lacquered ductile iron body
2. Adjustable Strainer – Stainless steel, aluminium or Nickel Bronze
3. Size of strainer :
Square: 4"x4", 6"x6", 8"x8" or 12"x12"
Round: 4", 6", 8", 12" \varnothing
4. Outlet Pipe Size :
A : 150 mm \varnothing
B : 100 mm \varnothing
C : 75 mm \varnothing
D : 50 mm \varnothing
5. Perforated stainless steel sediment bucket

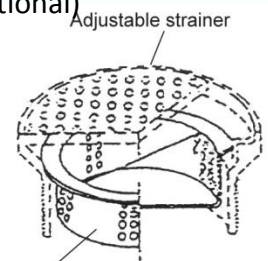

Perforated stainless steel sediment bucket

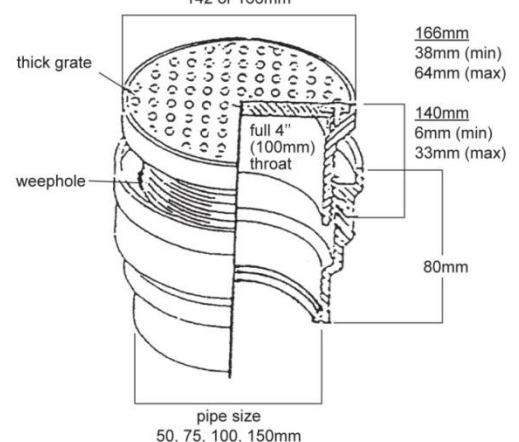

FROSCO LARGE FLOOR DRAIN (FFD 800 S&R SERIES)

BODY DUCTILE IRON / NICKLE BRONZE OR DUCTILE IRON STRAINER OR GRATING

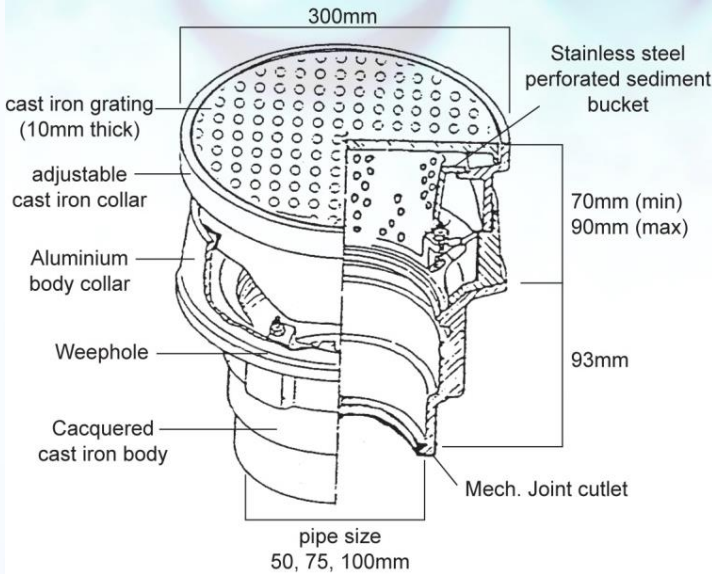

FFD-880R

1. Lacquered ductile iron grate (to specify thickness)
2. Lacquered Adjustable cast iron collar
3. Stainless Steel perforated sediment bucket
4. Lacquered ductile iron body
5. Outlet Pipe Size :
A : 100 mm \varnothing
B : 75 mm \varnothing
C : 50 mm \varnothing

FFD-890SQ

1. Lacquered ductile iron grate
2. Lacquered Adjustable cast iron collar
3. Aluminium body collar
4. Stainless Steel perforated sediment bucket
5. Lacquered ductile iron body
6. Outlet Pipe Size :
A : 100 mm \varnothing
B : 75 mm \varnothing
C : 50 mm \varnothing

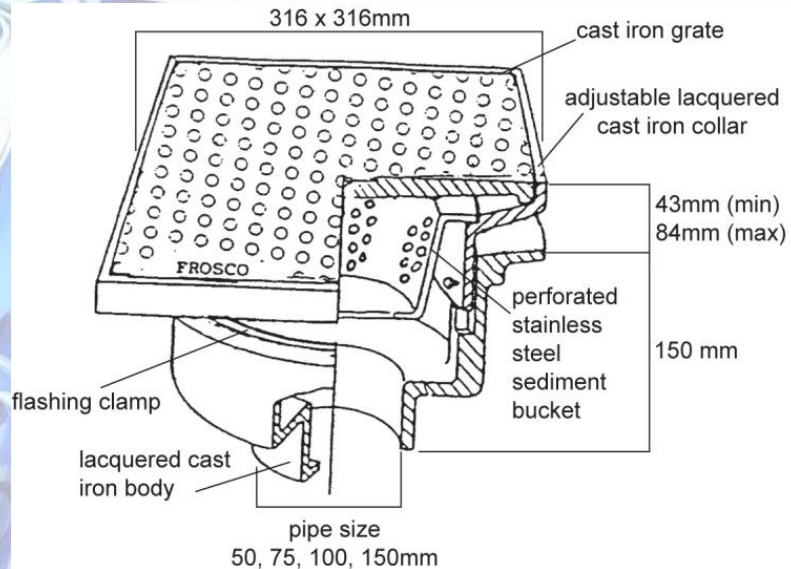

FROSCO Floor Gully S/P Trap MODEL (FFD-850ST, FFD-850PT)

Ductile Iron / Nickel Bronze or Ductile Iron Strain or Grating

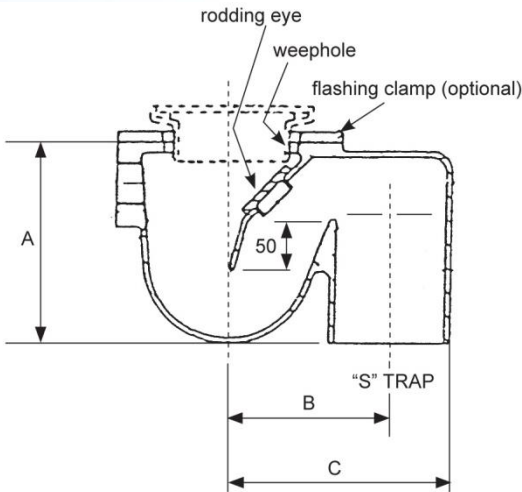
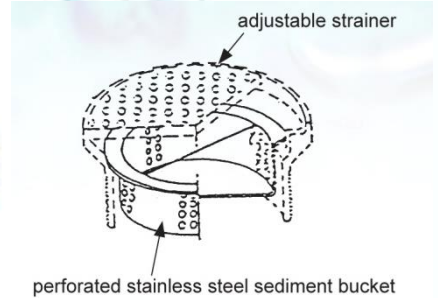
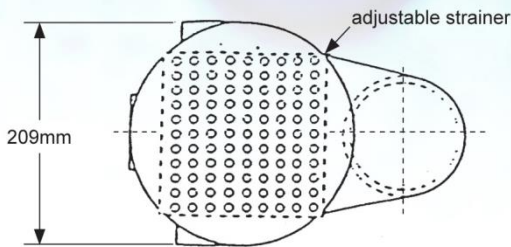

MODEL FFD-850ST

1. Adjustable Strainer = Nickel Bronze or Ductile Iron
2. Perforated Stainless Steel sediment bucket (optional)
3. Aluminium flashing clamp (optional)
4. Lacquered ductile iron body
5. Outlet Pipe Size : 75 mm ϕ or 100 mm ϕ
6. Multiple inlet connection

Outlet Pipe (mm)	A(mm)	B(mm)	C(mm)
100	196	152	214
75	170	126	188

MODEL FFD-850PT

1. Adjustable Strainer = Nickel Bronze or Ductile iron
2. Perforated Stainless Steel sediment bucket (optional)
3. Aluminium flashing clamp (optional)
4. Lacquered ductile iron body
5. Outlet Pipe Size :
75 mm ϕ or 100 mm ϕ
6. Multiple inlet connection

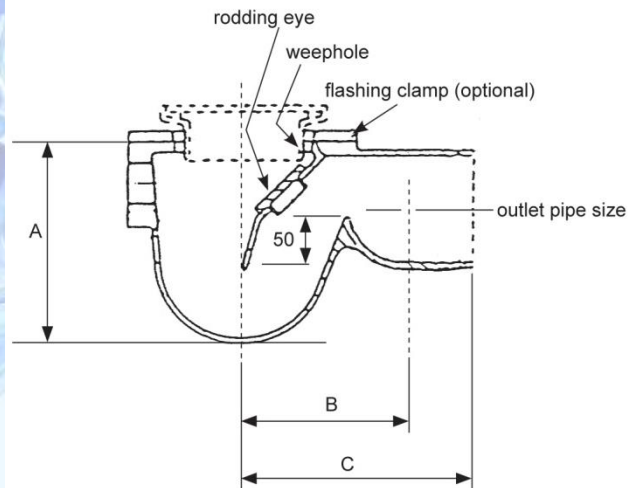

FROSCO SG-740 DT SERIES SEDIMENT GULLEY DEEP TRAPPED

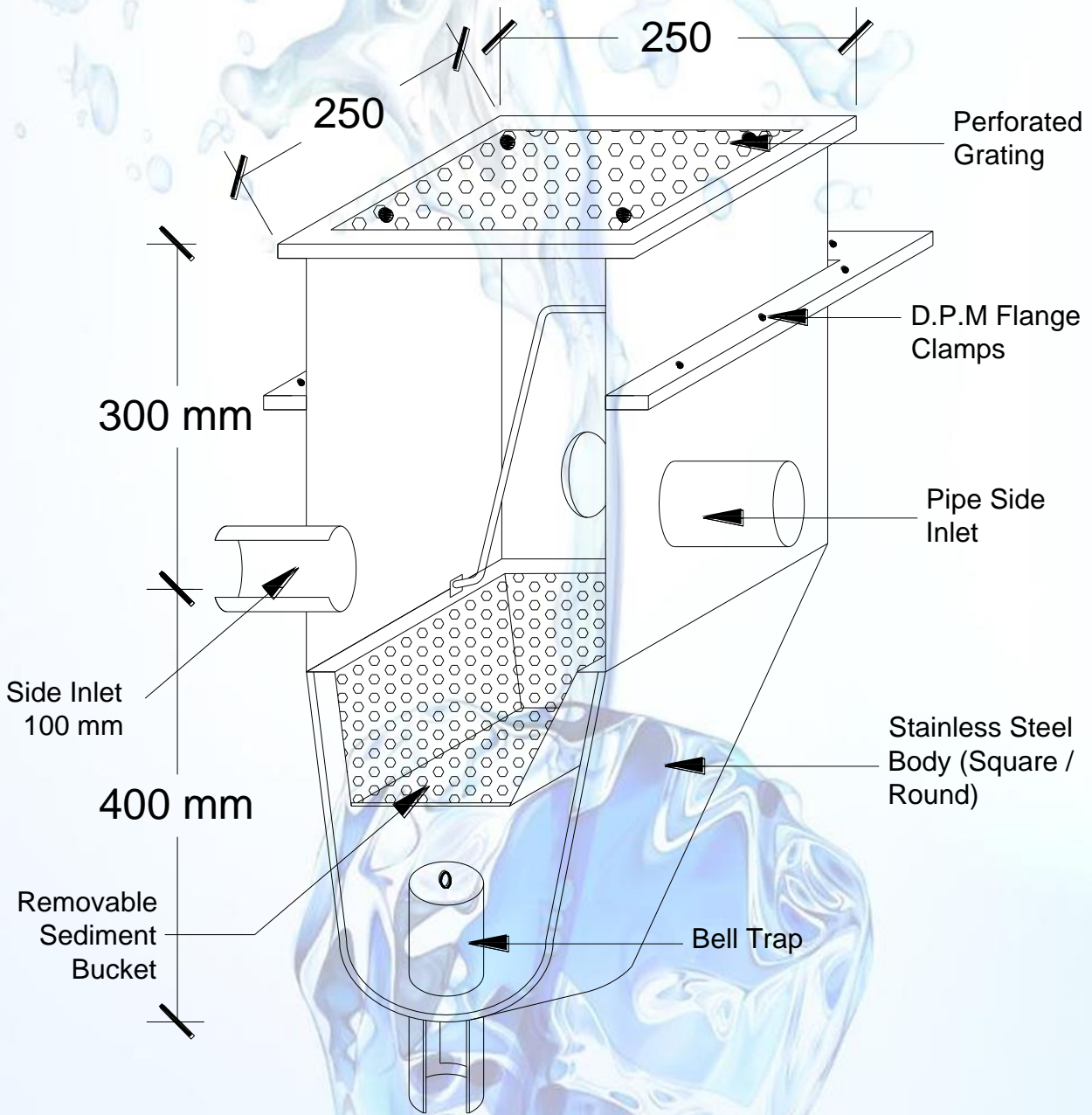

FROSCO stainless steel sediment gulley deep trapped completed with perforated bucket and removable bell trap to filter sediment waste or solid, vertical spigot outlet, stainless steel perforated cover complete with vandal resistant screws.

Backwater Valve (FBV-200)

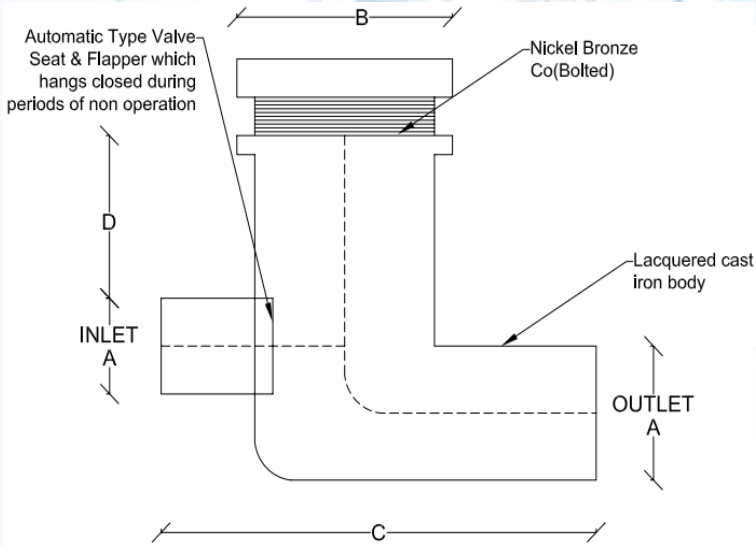

A Pipe Size (mm)	B (mm)	C (mm)	D (mm)
50	100	250	50
75	100	300	50
100	150	350	50
150	150	400	50
200	200	450	50
250	200	500	50

Variation in Strainer Design

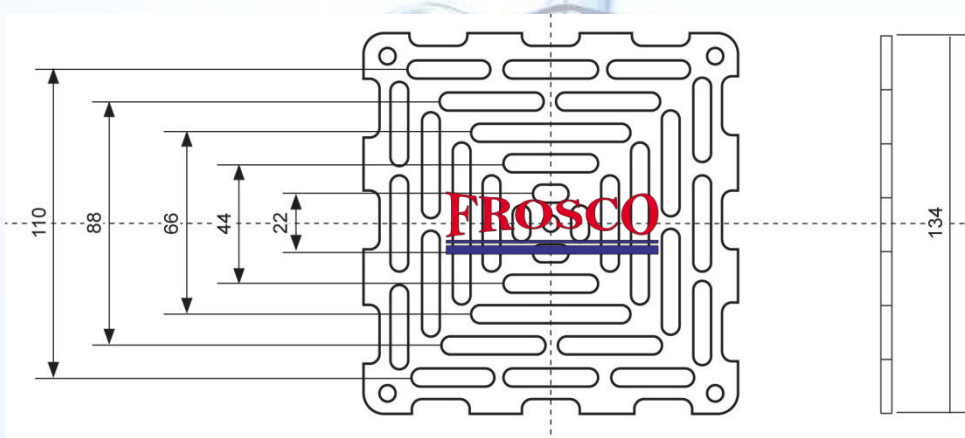

FroSCO Drain Grating

- Nickel Bronze
- Ductile Iron

FROSCO Rodding Eye / Clean-out (FRE-300)

1. FRE-300S (c/w square adjustable cover)
2. FRE-300R (c/w round adjustable cover)

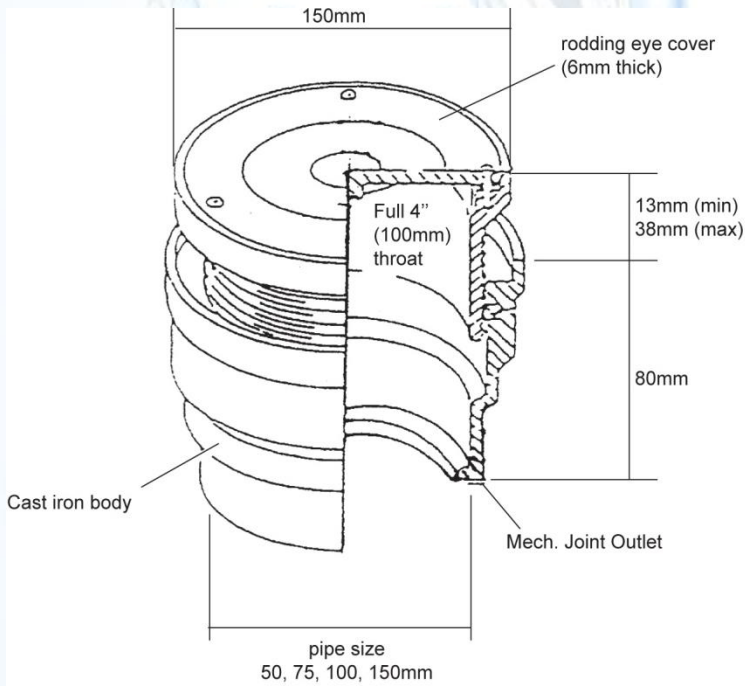

FRE-300

1. Rodding eye cover – stainless steel, nickel bronze or aluminium
2. Cast iron body
3. Outlet pipe size:
50, 75, 100 or 150mm

FROSCO Roof Drain MODEL (FRD-900) Body Cast Iron / Aluminium Dome Cover

FRD-900

1. Aluminium dome
2. Aluminum Flashing Ring with gravel stop
3. Perforated stainless steel sediment basket (optional)
4. Lacquered cast iron body
5. Outlet pipe size
(Available as follow)

OUTLET PIPE SIZE :

- A : 200 mm Ø (Inner)
- B : 150 mm Ø (Inner)
- C : 100 mm Ø (Inner)
- D : 75 mm Ø (Inner)**

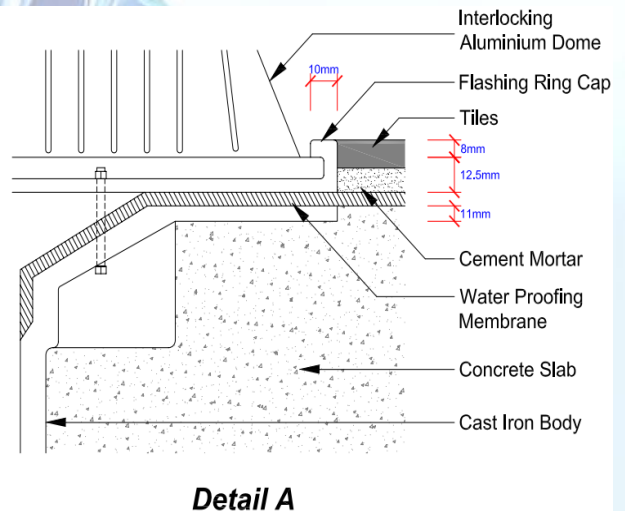
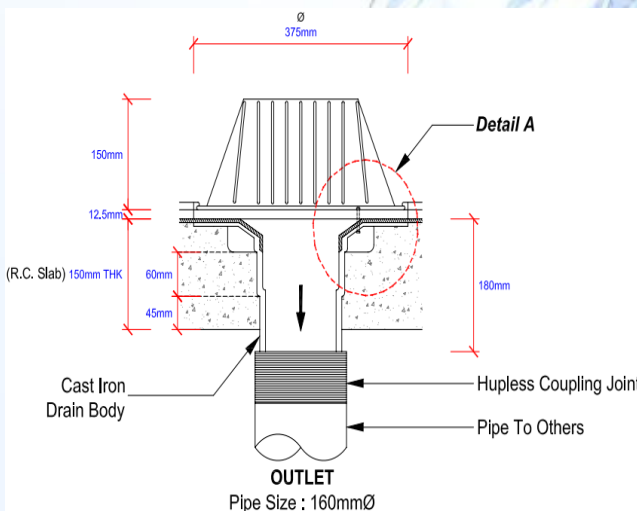
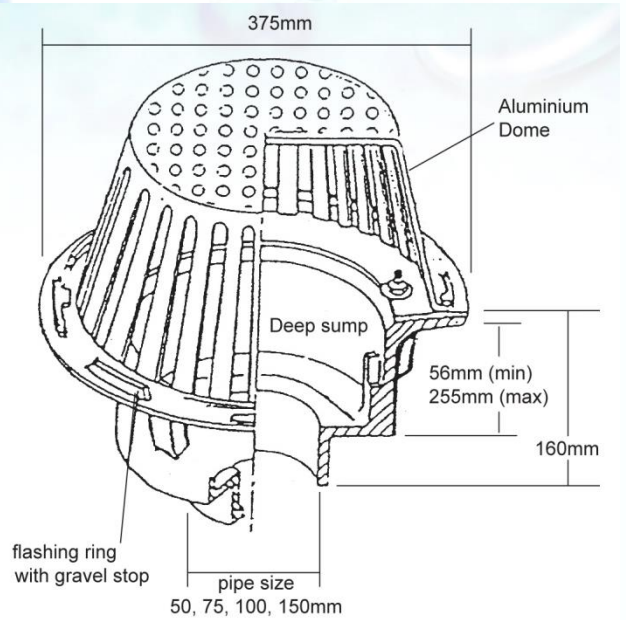

FROSCO ROOF DRAIN MODEL (FRD-700)

Body Cast Iron / Aluminium Dome Cover

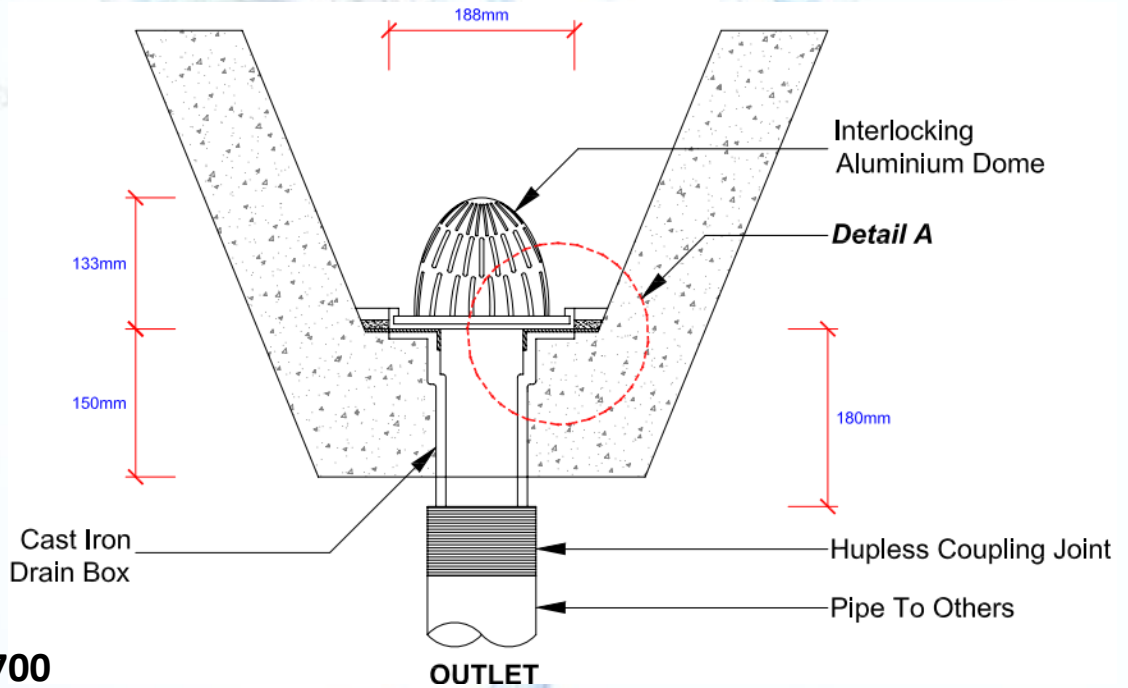

FRD-700

- Dome Size : 188 mm ϕ
- Interlocking Flashing Ring : 200 mm ϕ
- Body : 210 mm ϕ
- Pipe Size : (Available as Follow)

OUTLET PIPE SIZE :

- A : 150 mm ϕ (Inner)
- B : 100 mm ϕ (Inner)
- C : 75 mm ϕ (Inner)

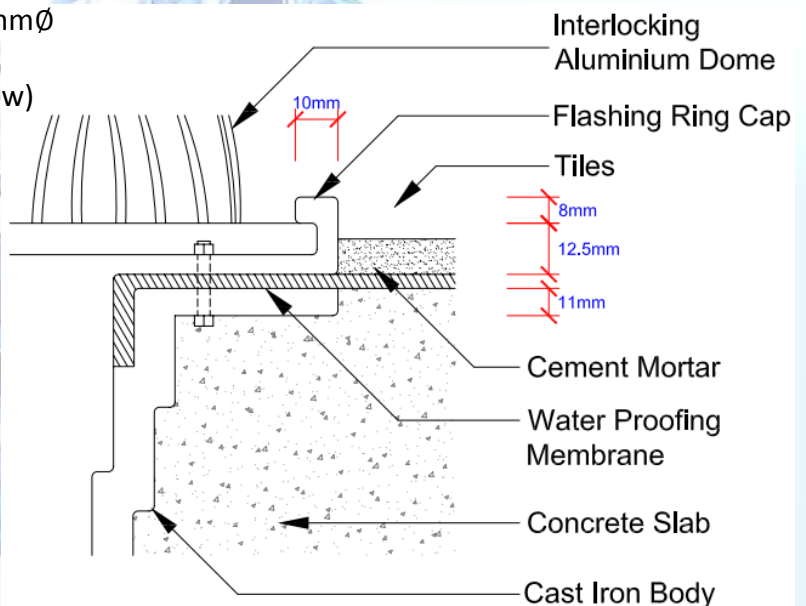

Detail A

INSTALLATION

1. FLOOR DRAIN

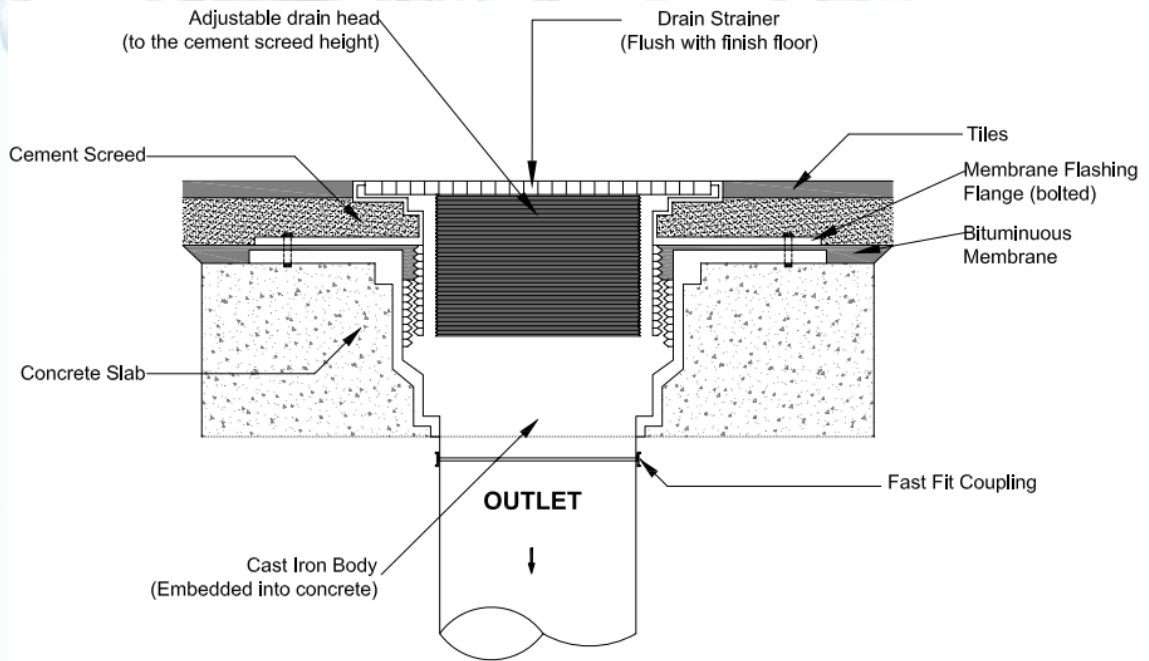

1. ROOF DRAIN

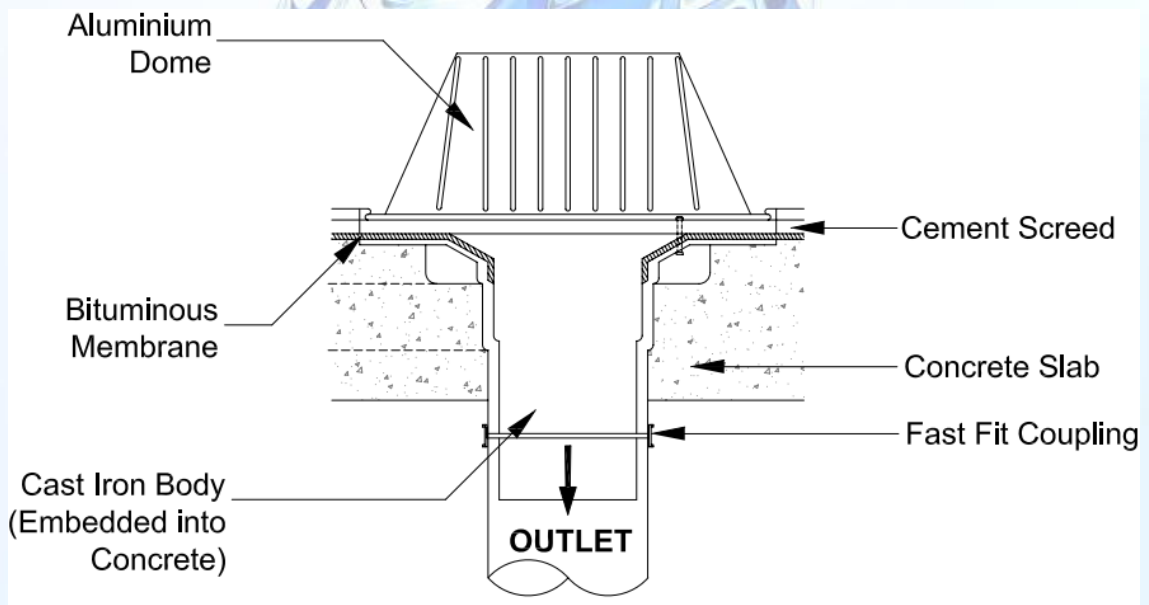

STAINLESS STEEL LARGE FLOOR DRAIN (LIGHT & MEDIUM DUTY) MODEL FD400L-SS

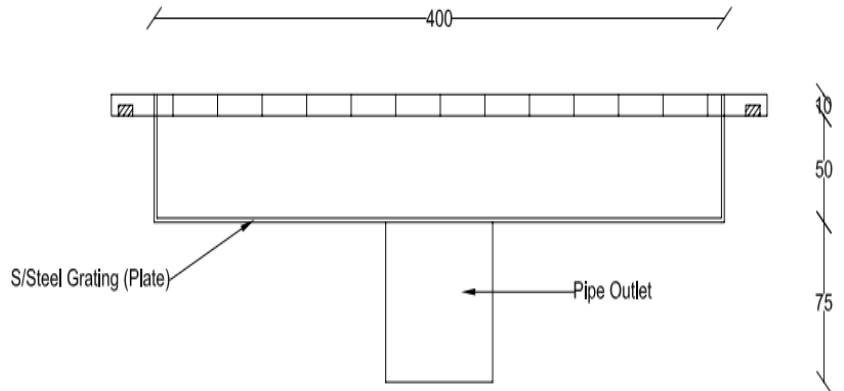
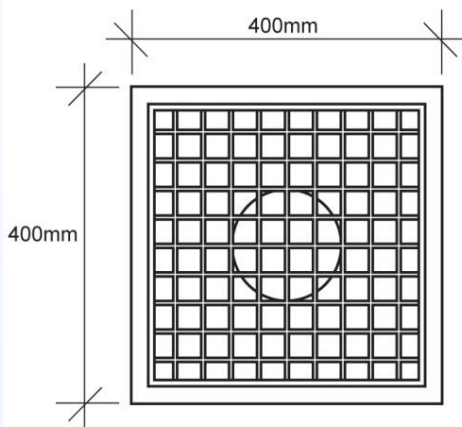
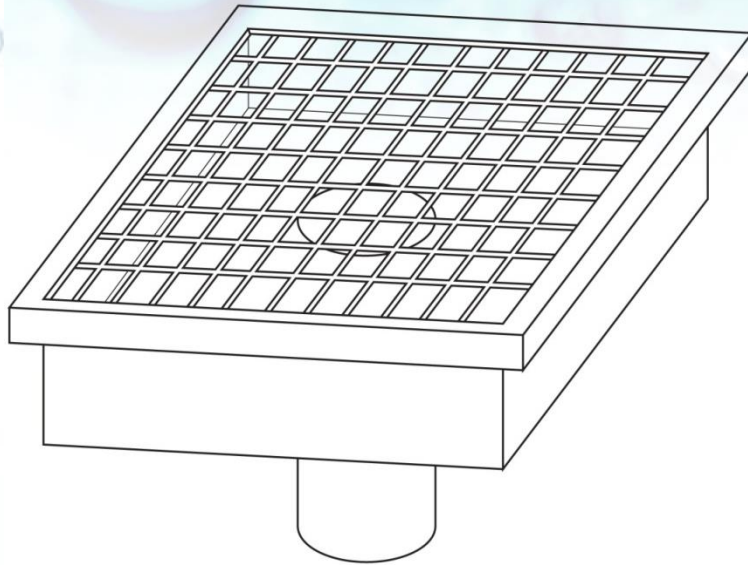

All dimension in mm

MODEL AND DRAIN SIZE AVAILABLE

FD 300L – SS / FD 300L - SSR

Size : 300 x 300 x 50mm(D)

FD 400L – SS

Size : 400 x 400 x 50mm(D)

FD 500L – SS

Size : 500 x 500 x 50mm(D)

Grating : Stainless Steel
Body : Stainless Steel
Outlet Pipe : Stainless Steel

Pipe Outlet Size :

A : 150 mm ϕ

B : 100 mm ϕ

C : 75 mm ϕ

D : 50 mm ϕ

FROSCO LIGHT & MEDIUM DUTY S/STEEL SEDIMENT WASTE DRAIN (MODEL: FSWD 335 BO-SS, FSWD SO-SS)

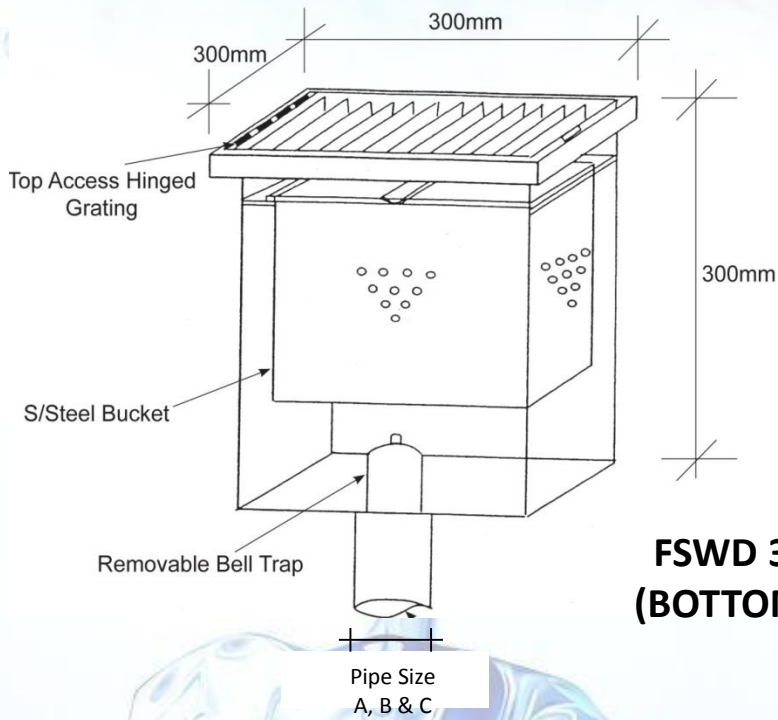

FSWD 335 SO-SS (SIDE OUTLET)

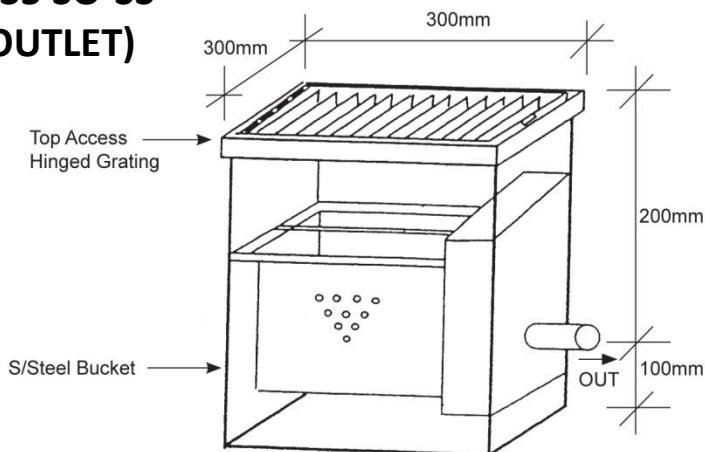

FROSCO WASTE DRAIN / FLOOR DRAIN (S/STEEL) FFD-100SS

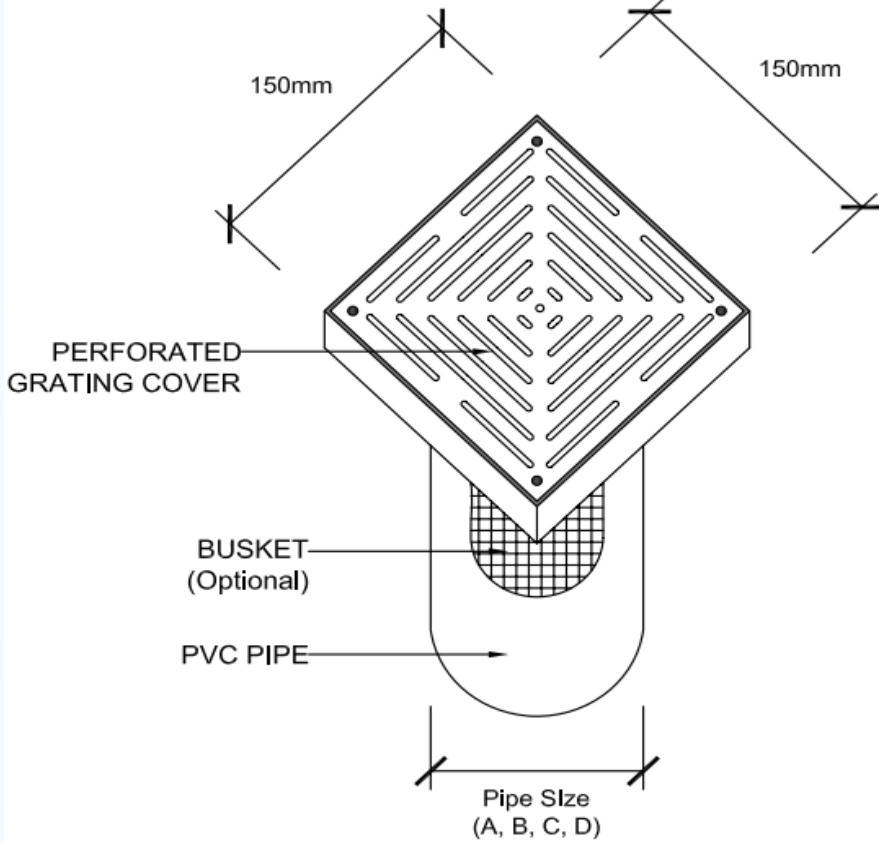

1. Stainless steel grate (Perforated or Tiles Topping)
(100 x 100 or 150 x 150)
2. Stainless steel body (Optional)
(100 x 100 or 150 x 150)
3. Stainless steel perforated sediment bucket (0.8mm)
4. Outlet pipe size :
A : 150 mm ϕ
B : 100 mm ϕ
C : 75 mm ϕ

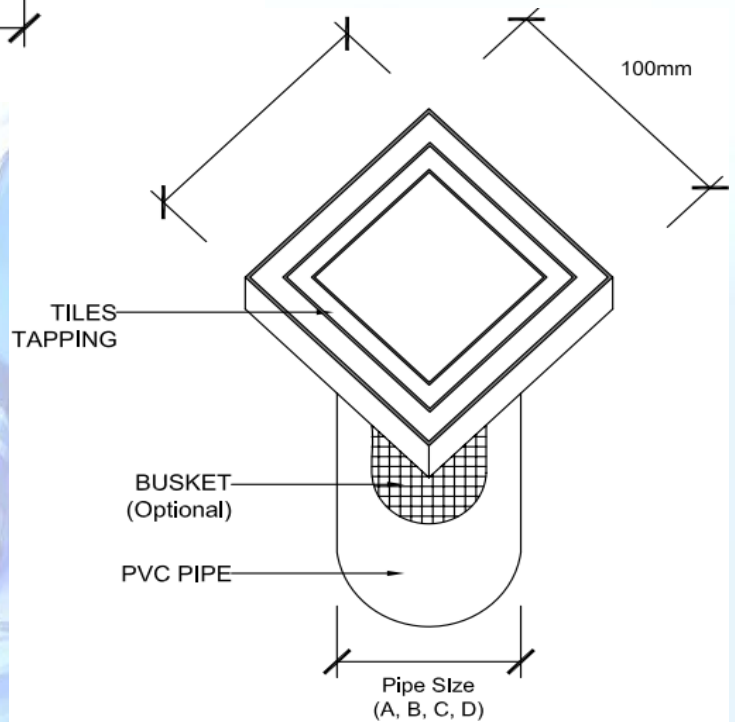

FROSCO ADJUSTABLE FLOOR DRAIN (S/STEEL) MODEL: FFD 388SS-SC/RG (SIZE: 300 x 300 x 300H)

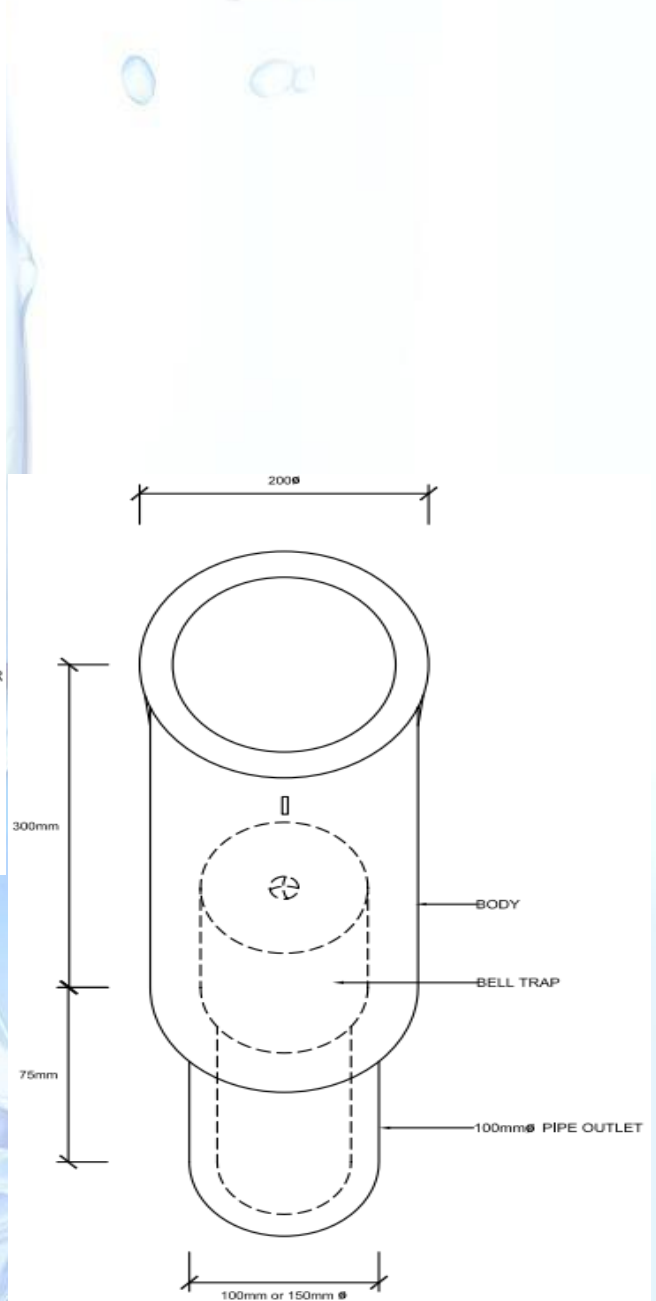
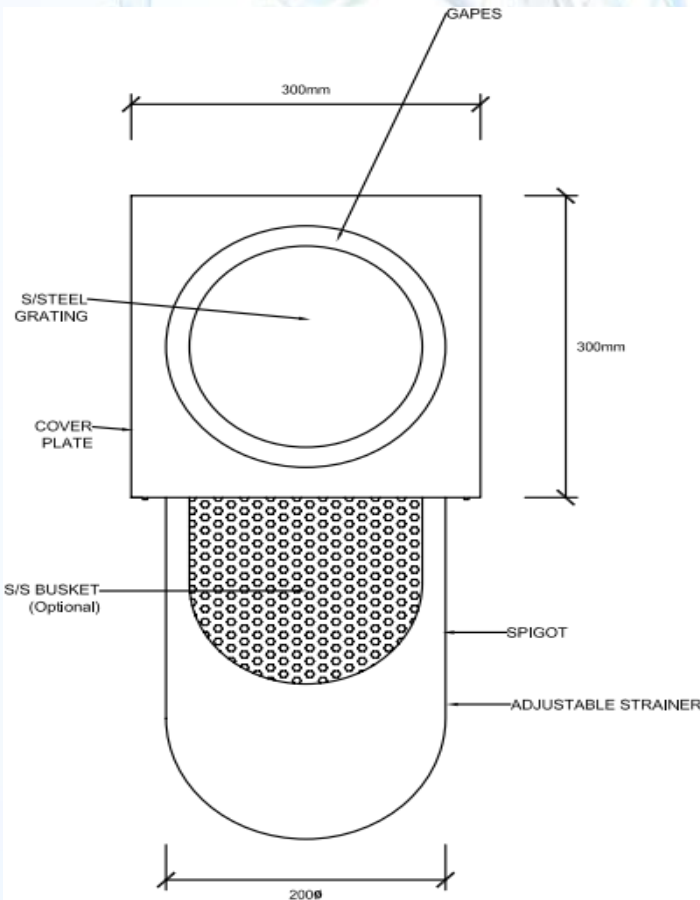

- Cover : Stainless Steel
- Body : Stainless Steel
- Strainer (Bucket): Stainless Steel
- Outlet Pipe : Stainless Steel
- Pipe Outlet Size : 200mm Ø

FROSCO

TOGETHER ENRICHING OUR ENVIRONMENT

STAINLESS STEEL

RAIN WATER HARVESTING

**Model
FRH 650**

Type (A)

1. Model : FRH 650
2. Size : 650mm (L) x 410mm (W) x 1800 mm (H)
3. Pipe Size : 100mmØ/ 150mm Ø

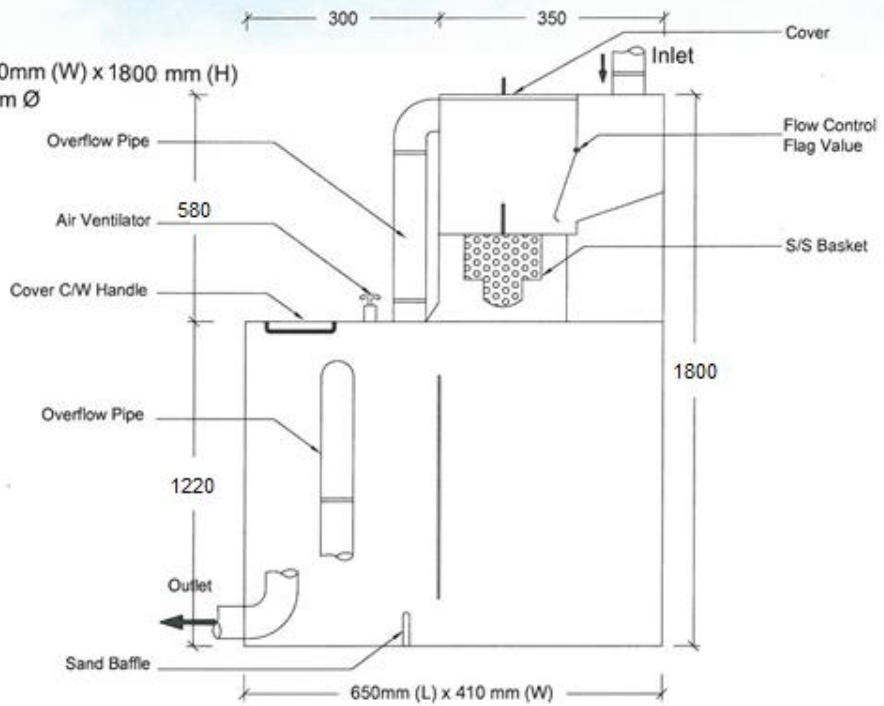

**Model
FRH 800XL**

Type (B)

1. Model : FRH 800XL
2. Size : 800mm (L) x 500mm (W) x 1800mm(H)
3. Pipe Size : 100mmØ / 150mmØ

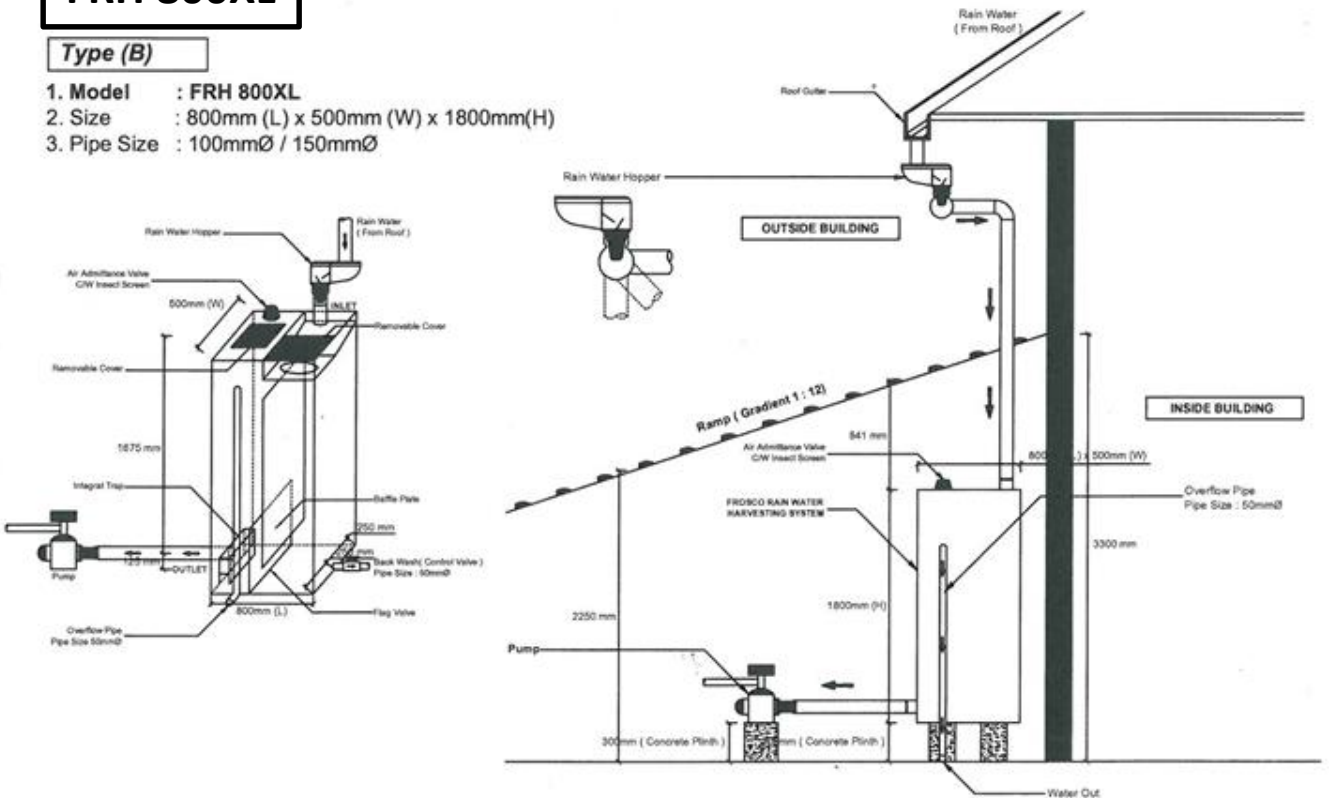

In keeping with our policy of updating products we reserve the right to make improvement or changes without notice.

MODEL : FESN 900 RAIN WATER HARVESTING TANK (STAINLESS STEEL)

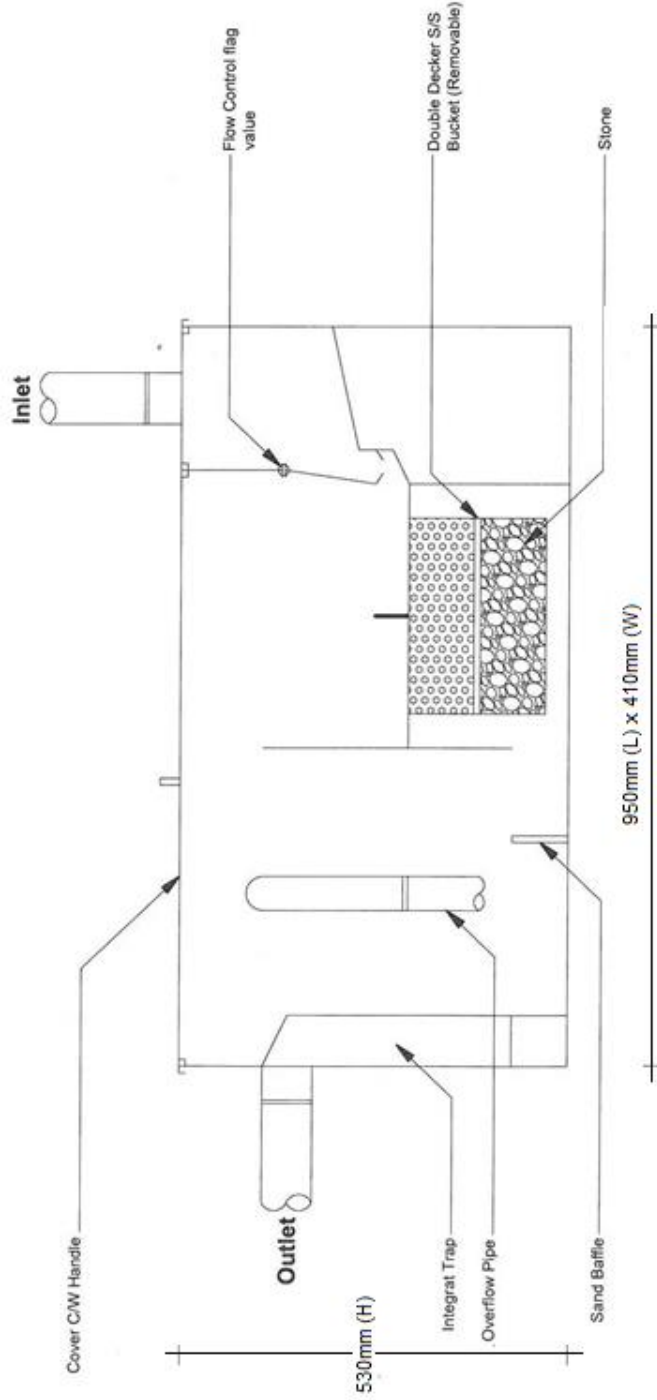

SIDE VIEW

NOTE:

MODEL: FESN 900 FROSCO
RAIN WATER HARVESTING TANK
Size: 950mm (L) x 410mm (W) x 530mm (H)
Flowrate: 1.9L/sec

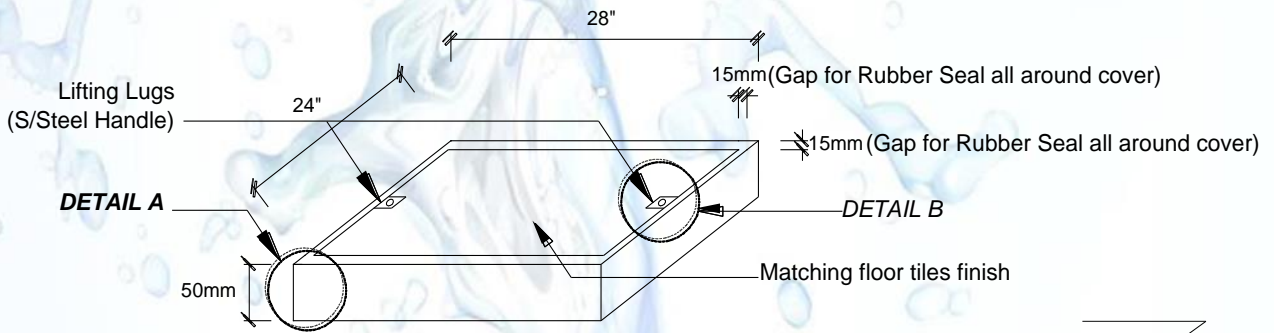

PICTORIAL VIEW
(Manhole Cover)

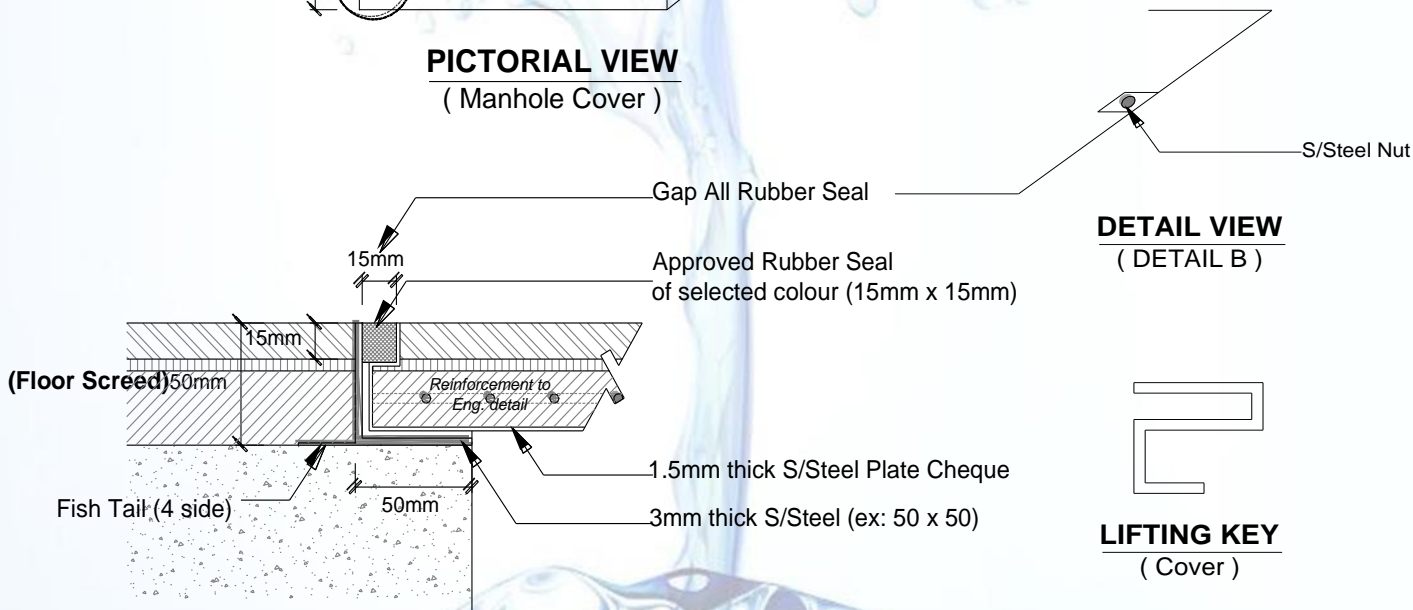

DETAIL VIEW
(DETAIL A)

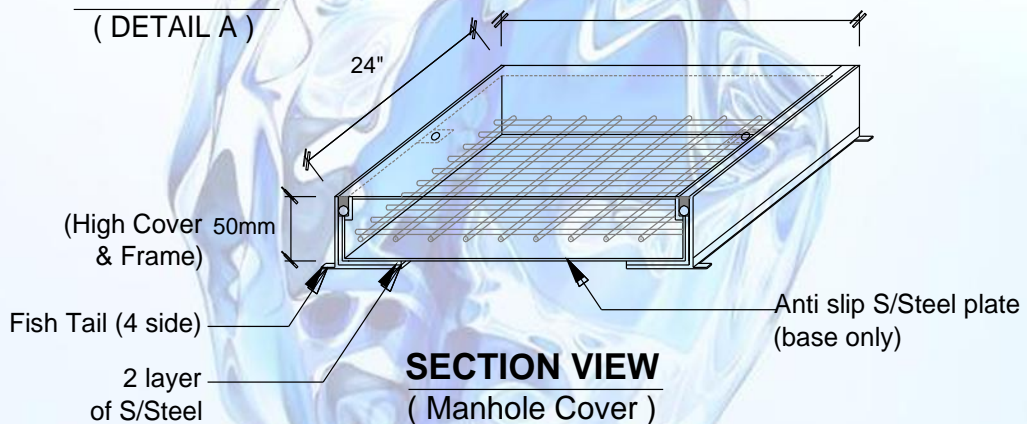

SUGGESTED VAPOUR SEALED MANHOLE COVER

NOTE :

Sealant need to be cut off & remove before cover removal & reseal with rubber seal continuous all round cover when cover in shut position again.

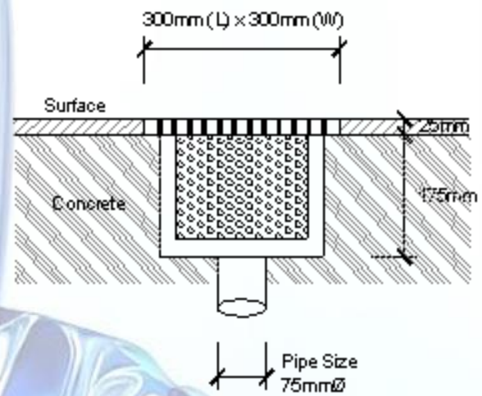
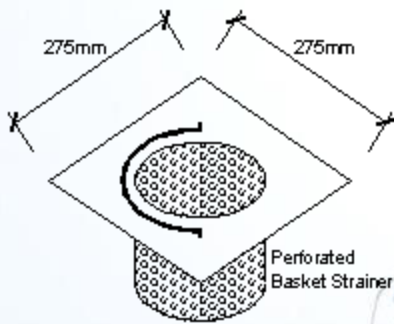
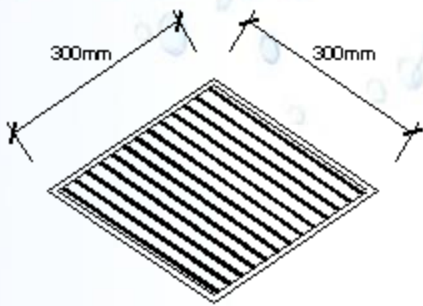

CROSS SECTION

Model : FED 333
Material : STAINLESS STEEL

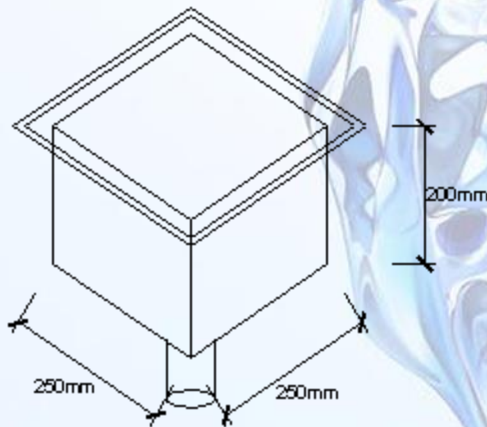

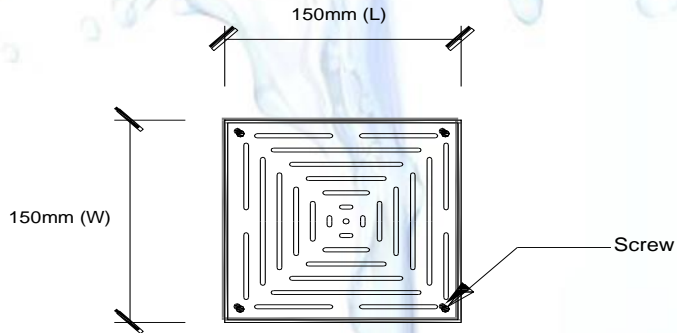

PLAN VIEW

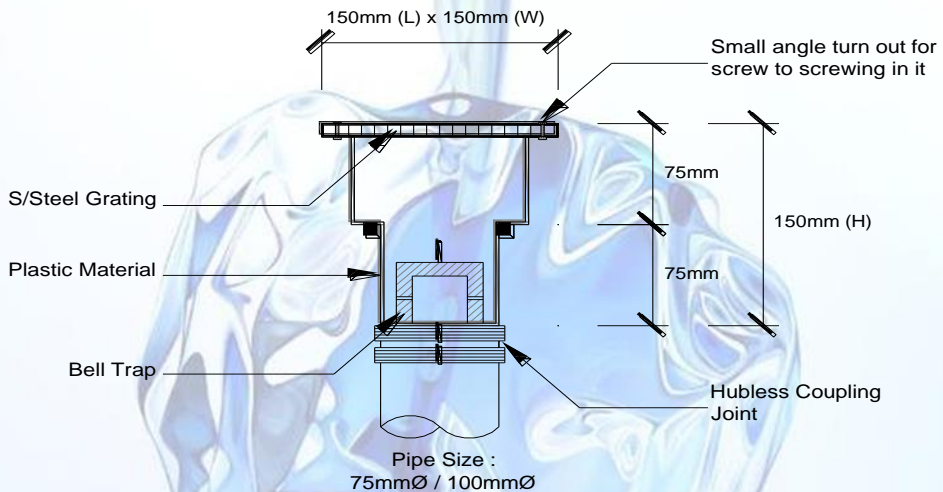

SECTION VIEW

NOTE : FroSCO Mini (Floor Drain)
Size : 150mm (L) x 150mm (W) x 150mm (H)
Pipe Size : 100 mmØ / 75mm Ø

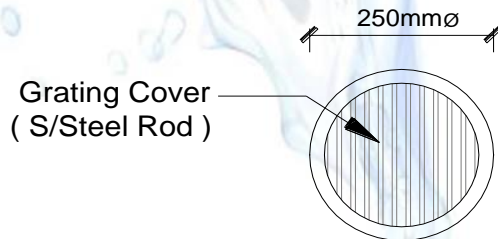

TOP VIEW
(FSWD 334 R-BO)

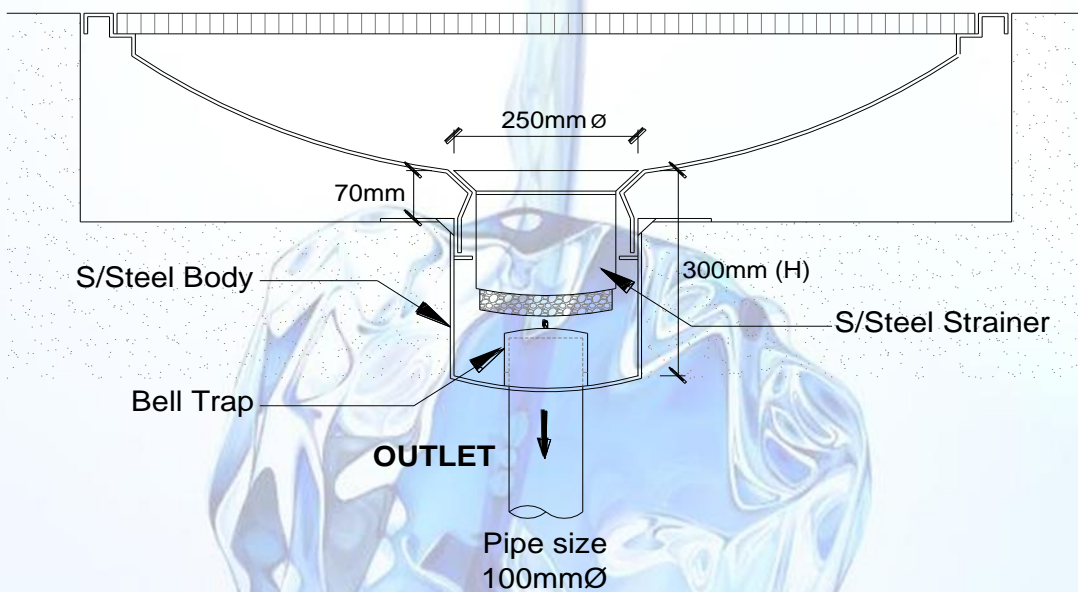

SECTION VIEW

NOTE : Froscos Waste Drain
Model : FSWD 334 R-BO
Size : 250 mm \varnothing x 300mm (H)

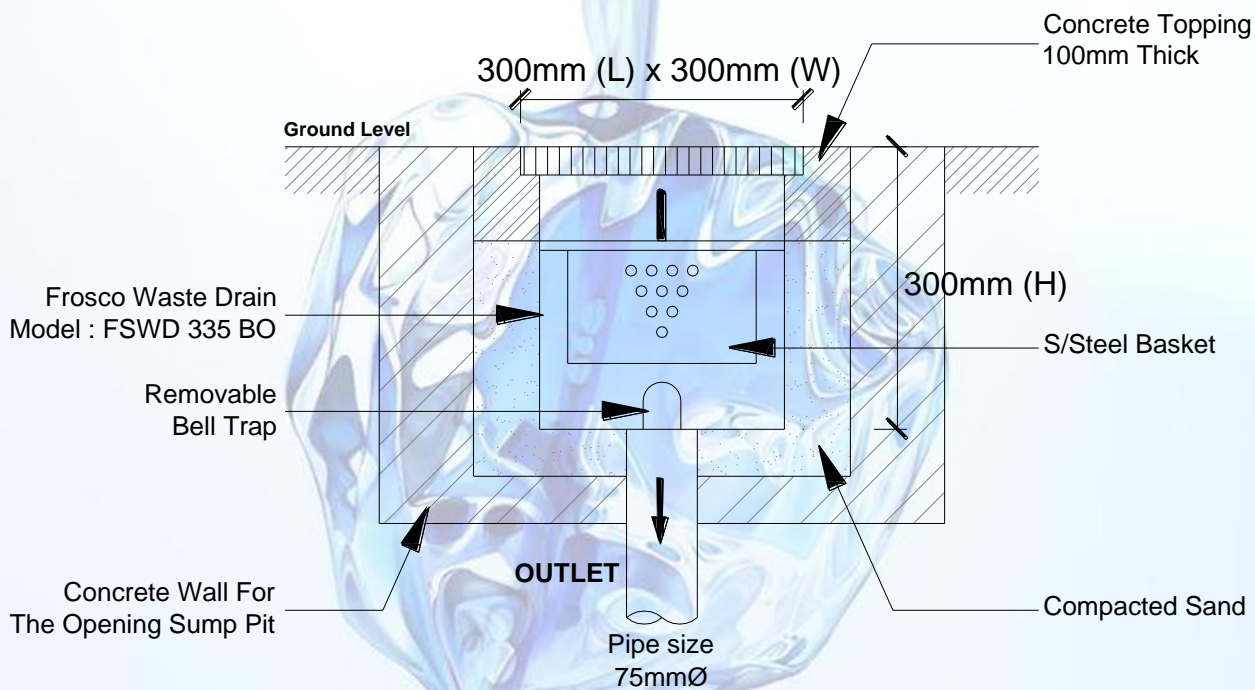
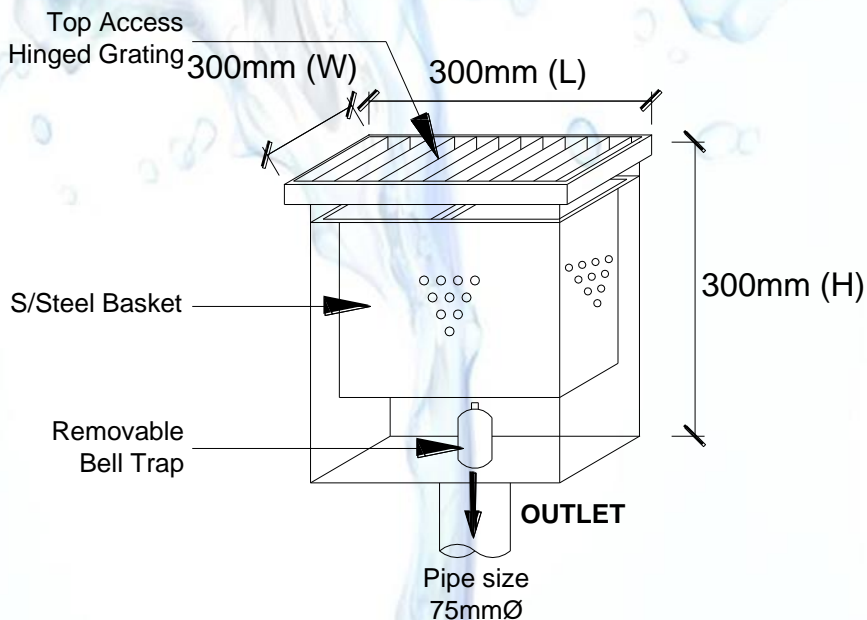

SECTION VIEW

(Detail Install)

FROSCO

TOGETHER ENRICHING OUR ENVIRONMENT

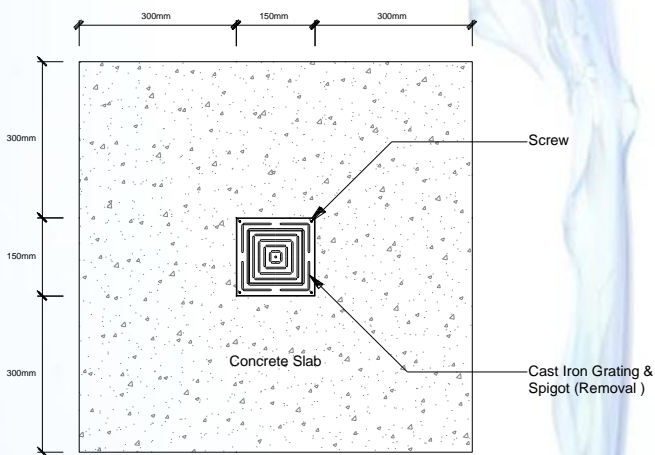

PLAN VIEW

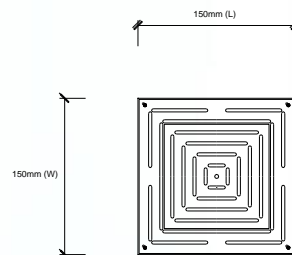

Cast Iron Grating & Spigot (Removal)

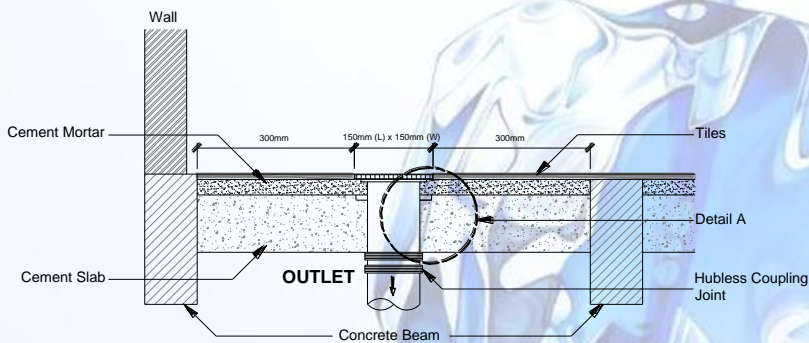

SECTION VIEW

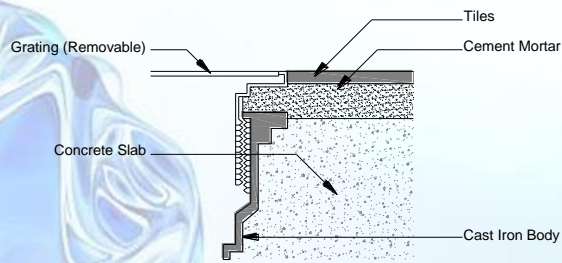

Detail A

NOTE : FROSCO FLOOR DRAIN

Model : FFD 820 Series

Size : 150mm (L) x 150mm (W) x 150mm(H)

Pipe Size : 150mmØ / 100mmØ

FROSCO

TOGETHER ENRICHING OUR ENVIRONMENT

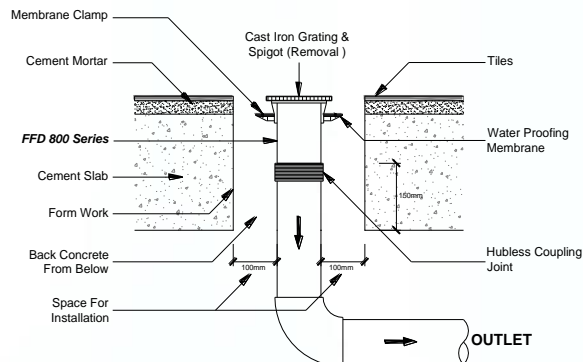
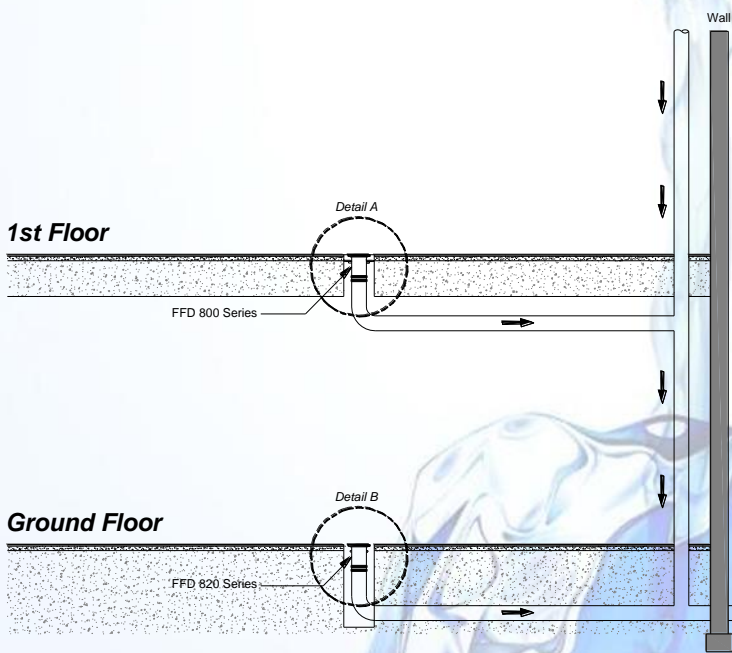

Detail A
(FFD 800 Series)

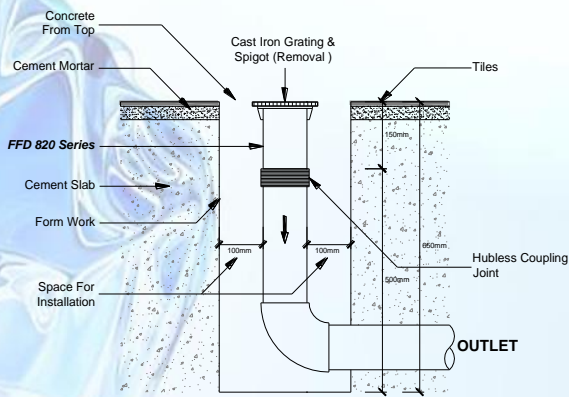

Detail B
(FFD 820 Series)

**NOTE : FROSCO FLOOR DRAIN
Installation Guide**

FROSCO

TOGETHER ENRICHING OUR ENVIRONMENT

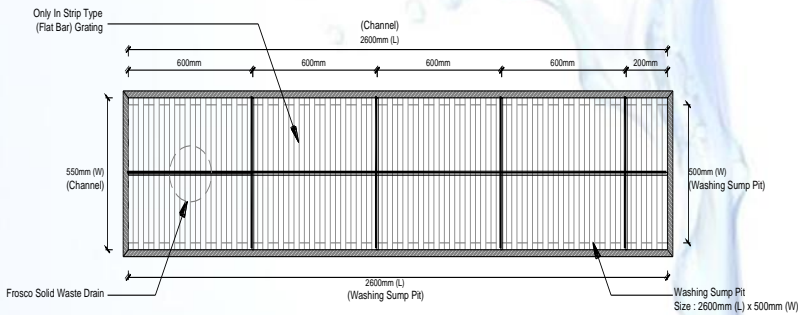

TOP VIEW

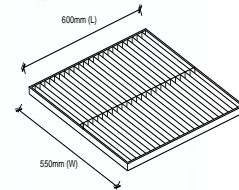

Standard Size Grating

Grating (500mm) + Frame (50mm - Both Side) = Total Width (550mm)

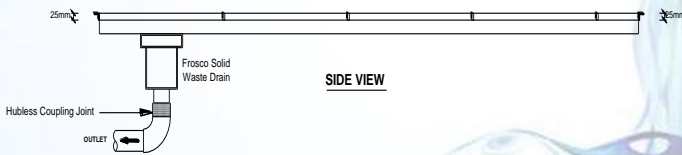

SIDE VIEW

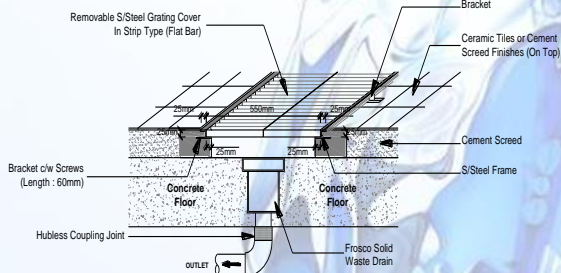

SECTION VIEW

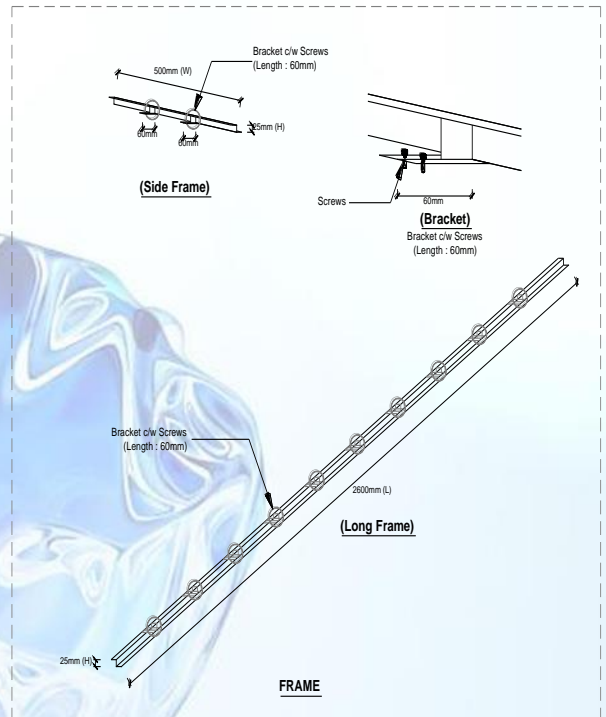

Note : Washing Sump Pit (Channel) S/Steel Grating Cover c/w Frame (Stainless Steel)

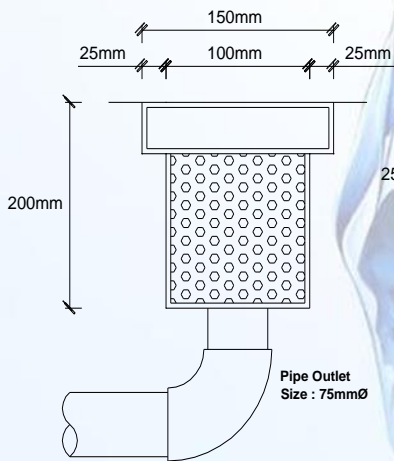
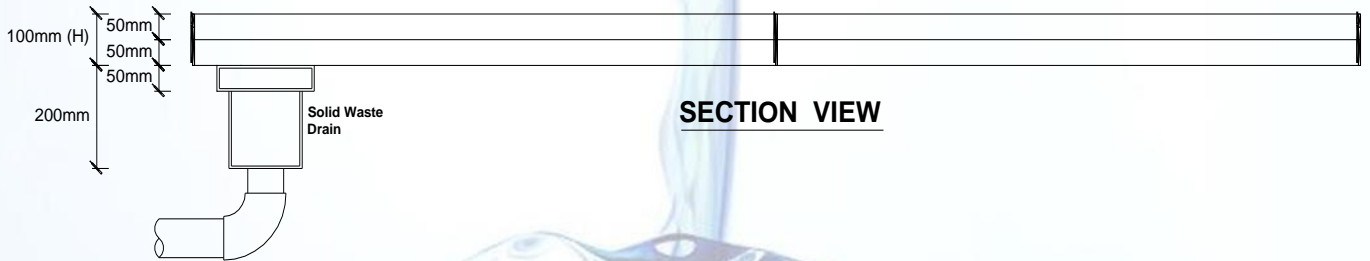
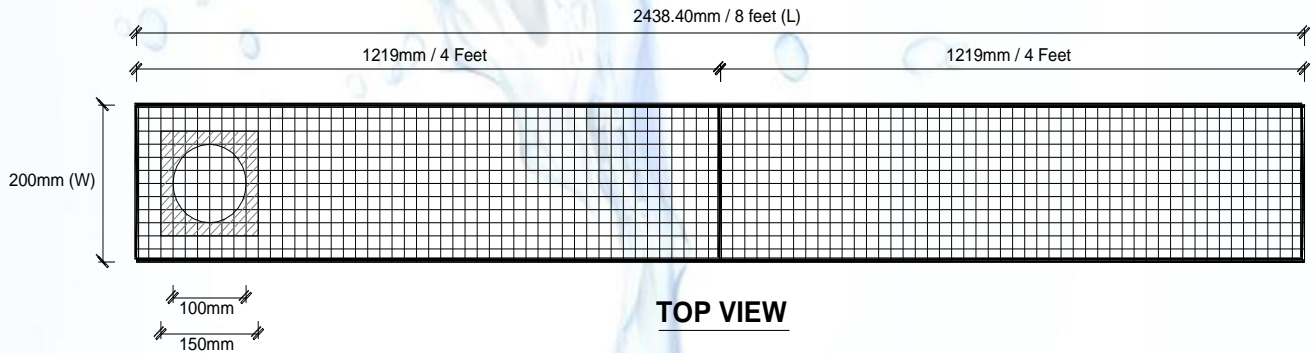

TOP VIEW
(Size Of Each Square)

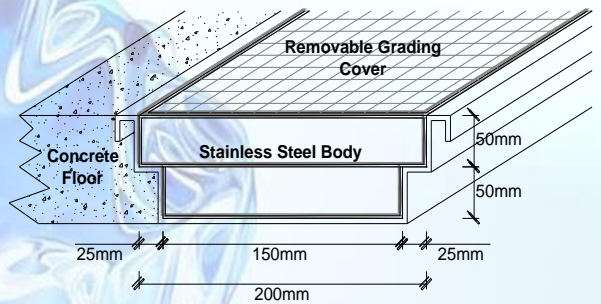

Stainless Steel Drainage Channels

Size : 2438.40mm / 8 feet (L) x 200mm / 1 feet (W) x 100mm (H)
Body Bending 'U' Shape

Industrial Drains

FOR VINYL COVERING

FROSGOLD



AN INDUSTRIAL FLOOR
DRAIN FOR VINYL COVERING

The **FROSGOLD** Industrial floor drain range in stainless steel developed for used in hygiene sensitive areas and corrosive environments.

- Circular clamping ring & grating
- 75, 110 & 160mm outlet sizes



Type No. FD880.xxx.s/s
Bottom Outlet



Type No. FD885.xxx.s/s
Side Outlet

- 4 different type of grating

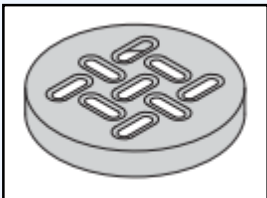

3mm
Punched
Grating



5mm Slot
Grating



25/5mm
Ladder
Grating

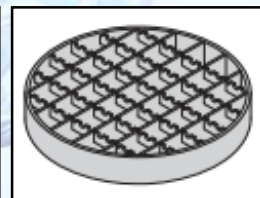

25/3mm
Mesh
Grating

- Stainless steel industrial drains for vinyl covering

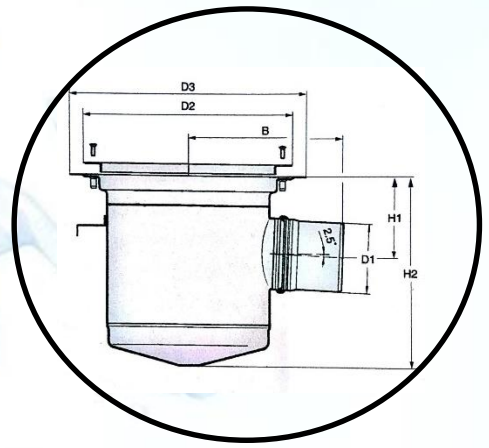
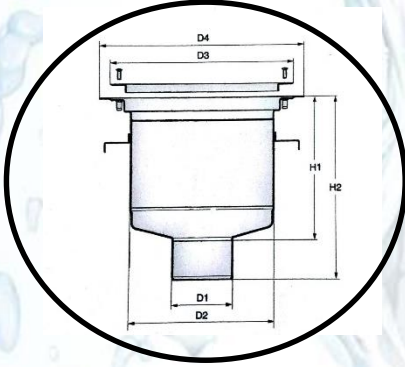

Industrial Drain With Bottom Outlet						
Type No	D1	D2	D3	D4	H1	H2
FD880.232.075	75	160	232	275	225	285
FD880.232.110	110	160	232	275	220	290
FD880.232.110	110	260	332	375	267	337
FD880.232.160	160	260	332	375	262	352

Industrial Drain With Side Outlet						
Type No	D1	D2	D3	D4	H1	H2
FD885.232.075	75	232	275	185	108	226
FD885.232.110	110	232	275	195	126	226
FD885.232.110	110	332	375	245	127	303
FD885.232.160	160	332	375	279	154	303

GRATINGS :

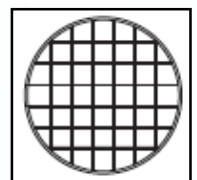
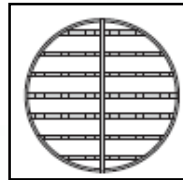
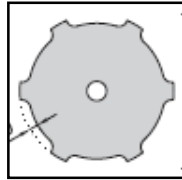
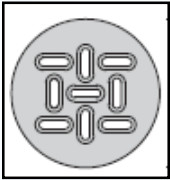

Type No	Dia.
FDG890.173/03	173
FDG890.273/03	273

Type No	Dia.
FDG890.173/05	173
FDG890.273/10	273

Type No	Dia.
FDG890.173/25	173
FDG890.273/25	273

Type No	Dia.
FDG890.173/224	173
FDG890.273/224	273

REMOVABLE WATER TRAP FOR BOTTOM OUTLET

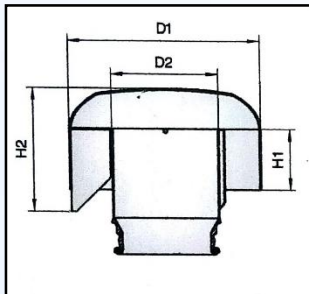

Type No	D1	D2	H1	H2
F760BO.200/110 S/S	116	75	62	101
F760BO.300/110 S/S	197	160	62	125
F760BO.300/160 S/S	197	160	62	125

REMOVABLE WATER TRAP FOR SIDE OUTLET

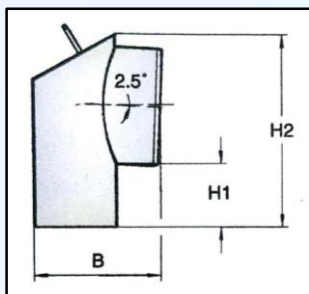

Type No	B	H1	H2
F765SO.200/110 S/S	109	60	122
F765SO.300/110 S/S	114	60	181
F765SO.300/160 S/S	124	60	181

For further information please contact:

FROSGOLD
VTSB TRADING

12, Jalan TIB 1/3, Taman Industri Bolton,
68100, Batu Caves, Selangor, Malaysia.
Tel : 03-6185 9262 Fax : 03-6185 9279
Email : work@froscoweb.com /
frosco99@yahoo.com
www.froscoweb.com

NO	PRODUCTS	CAT/PAGE DALLMER	CAT/PAGE FROSCO
1	AIR ADMITTANCE VALVES	328	PLASTIC FAAV001
2	ROOF DRAINS	280	2 / 9
3	RENOVATION ROOF DRAINS	289	10
4	SIPHONIC ROOF DRAINAGE	291	NONE
5	SHOWER TRAP	344	14
6	BALCONY AND TERRACE DRAIN	294	3
7	CAST IRON DRAINS	228	4
8	COMPLETE DRAIN ASSEMBLIES	193	5
9	FIRE AND PROOFING COLLAR	272	5
10	CERADRAIN COMPLETE DRAINS	260	4
11	CONCEALED TRAP FOR WASH BASIN	340	STCP / PG8
12	RAINWATER HOPPERS	309	16 / 17 / STCP PG 12
13	URINAL TRAPS	335	NONE
14	INTELLIGENT FLUSHING SYSTEM	363	NONE
15	CONCEALED TRAP FOR WASHING MACHINE	336	STCP / PG 7
16	YARD DRAINS	304	5 / 27 / 28
17	NASEMENT DRAINS AND KLENKMATIK	314	6/6A/22/27
18	PRONTO FLOOR DRAIN	321	14/15/19/20/21
19	ANTI-FLOODING VALVES	311	7 / 25 /26
20	RODDING EYES	324	8 / 28

NOTE : STCP = STORMCEPTOR CATALOGUE

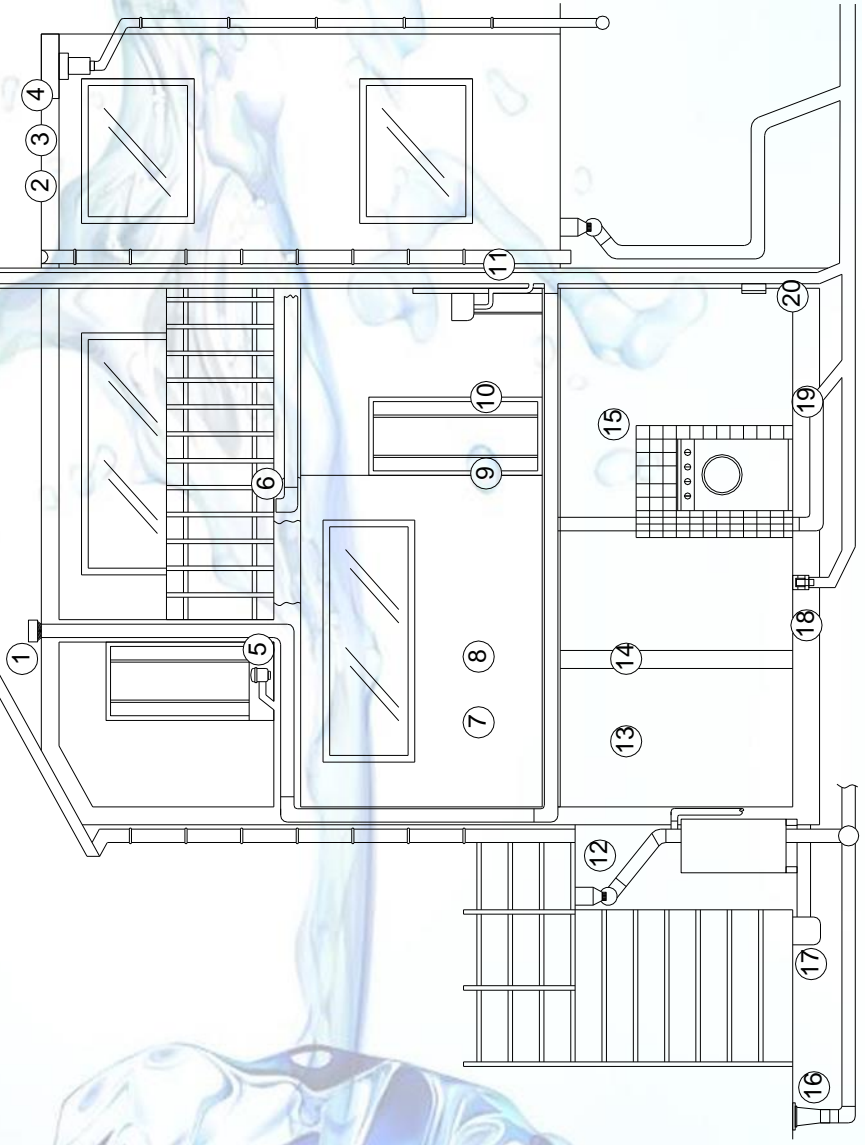

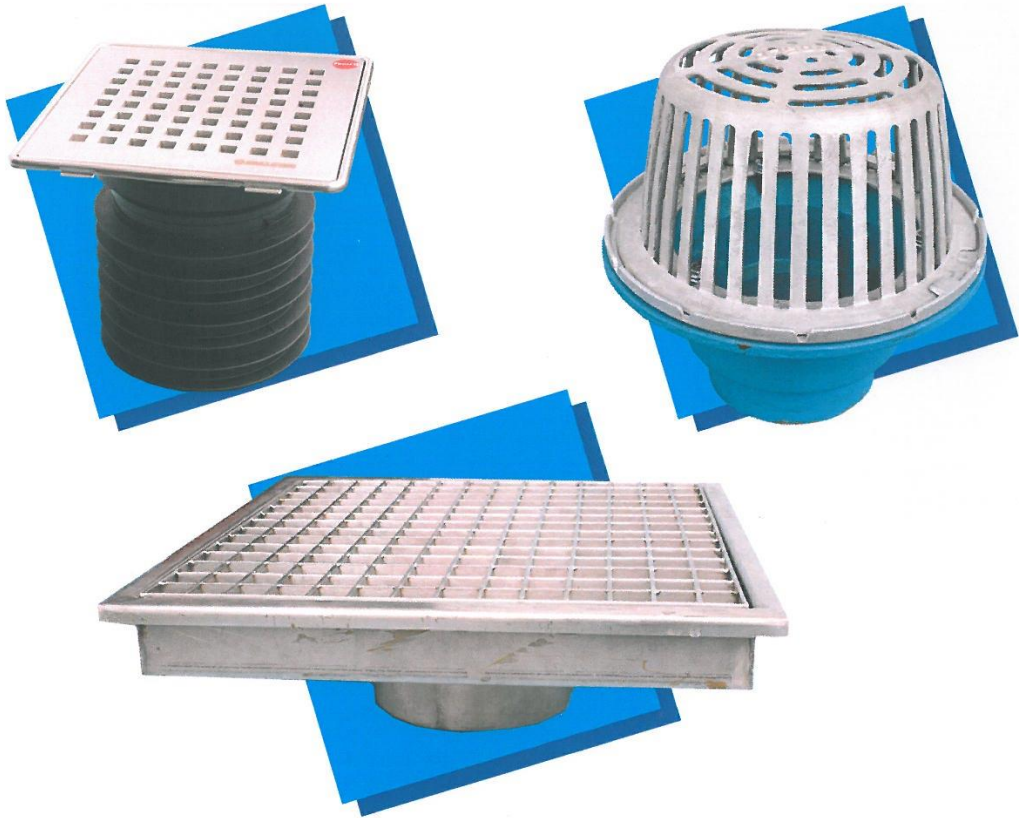

Sole Distributor :

VTSB Trading
12, Jalan TIB 1/3
Taman Industri Bolton
68100 Batu Caves, Selangor

Manufacturer :

K C Engineering Sdn Bhd (844804-X)
12, Jalan TIB 1/3
Taman Industri Bolton
68100 Batu Caves, Selangor

Tel : 03-6185 9262 (Hunting Line)

Fax : 03-6185 9279

Website : www.froscoweb.com

Email : work@froscoweb.com, sales@froscoweb.com

FROSGOLD